

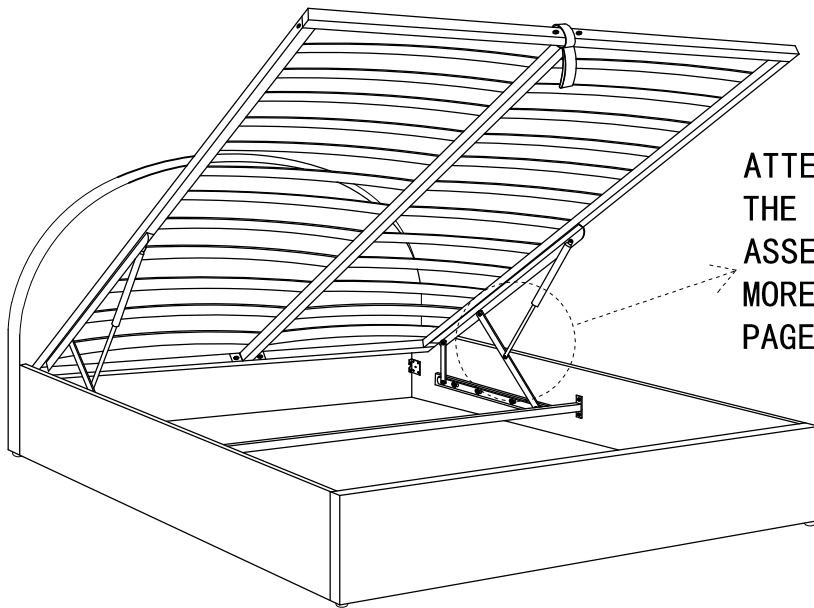

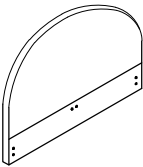

ASSEMBLY INSTRUCTIONS

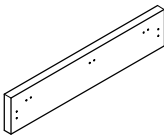

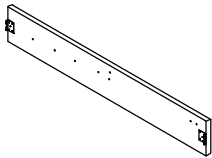
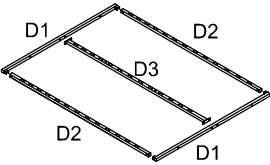
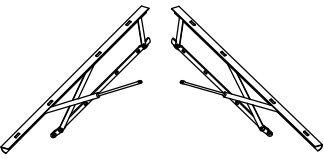



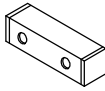
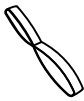
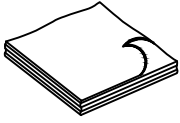
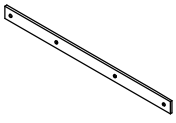
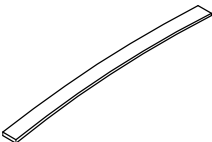
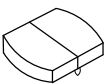
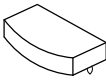



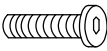





ATTENTION: PLS DO NOT PRESS/CLOSE THE GAS LIFT ROD BY HAND BEFORE ASSEMBLING ON BED FRAME. MORE INSTRUCTION PLS SEE LAST PAGE COMMENT.





PARTS LIST

<p>A: HEADBOARD 1PC</p> 	<p>B: FOOTBOARD 1PC</p> 	<p>C: SIDE RAIL 2PCS LEFT AND RIGHT</p> 	<p>D: METAL SLAT FRAME KD 1SETS</p> 
<p>E: GAS LIFT HINGES LEFT AND RIGHT 2PCS</p> 	<p>F: CORNER BRACKET 2PCS</p> 	<p>G: HORIZONTAL BAR 1PC</p> 	<p>H: MATTRESS STOPPER 2PCS</p> 
<p>I: SUPPORT BLOCK 2PCS</p> 	<p>J: ROPE 1PC</p> 	<p>K: NON-MOVEN BED BASE 1PC</p> 	<p>L: SIDEBAR 2PCS</p> 
<p>M: SLAT 26PCS</p> 	<p>N: DOUBLE PLASTIC CAP 13PCS</p> 	<p>O: SLAT CAP 26PCS</p> 	

HARDWARE LIST



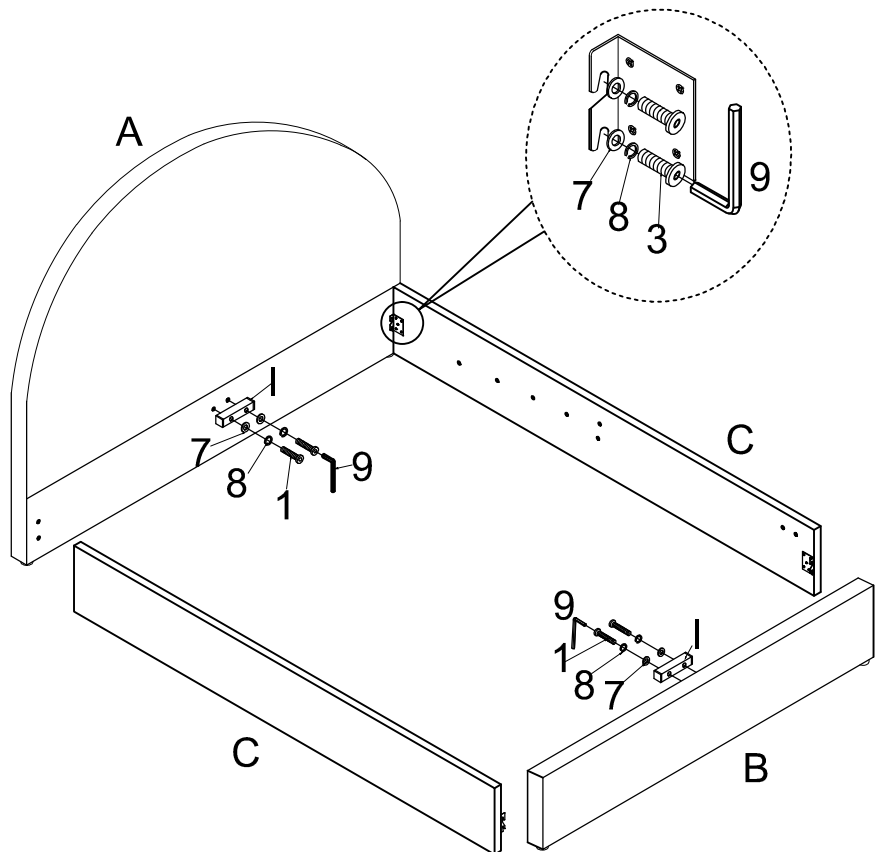

1: BOLT 4PCS  M8X55mm	2: BOLT 14PCS  M8X45mm	3: BOLT 8PCS  M8X30mm	4: BOLT 8PCS  M6X40mm	5: BOLT 12PCS  M6X20mm
6: NUT 14PCS  M8	7: FLAT WASHER 26PCS  M8	8: SPRING WASHER 26PCS  M8	9: ALLEN KEY 1PC  M8	10: SPANNER 1PC 
11: FLAT WASHER 20PCS  M6	12: SPRING WASHER 20PCS  M6	13: ALLEN KEY 1PC  M8	14: ALLEN KEY 1PC  M6	

STEP 1

1		4PCS
		M8X55mm
3		8PCS
		M8X30mm
7		12PCS
		M8
8		12PCS
		M8
9		
		M8





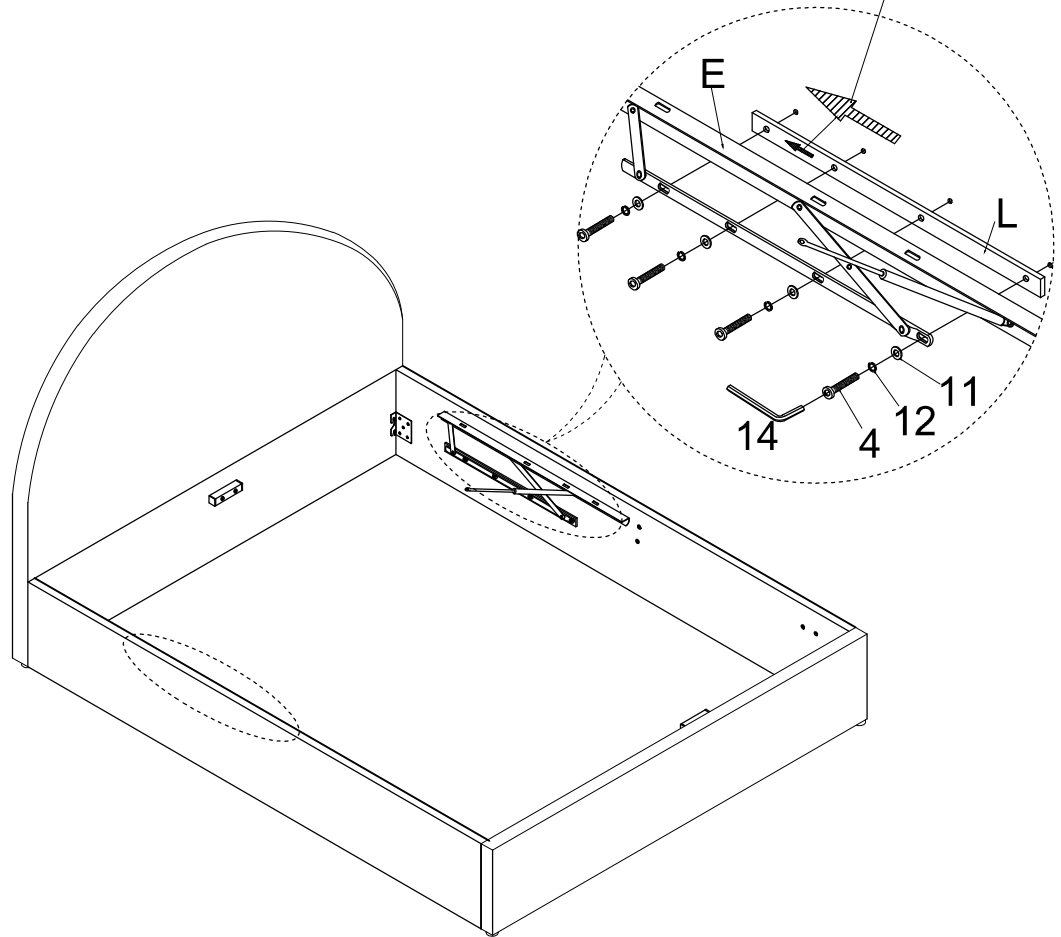

STEP 2

4		8PCS
	M6X40mm	
11		8PCS
	M6	
12		8PCS
	M6	
14		
	M6	

ARROW TO HEADBOARD







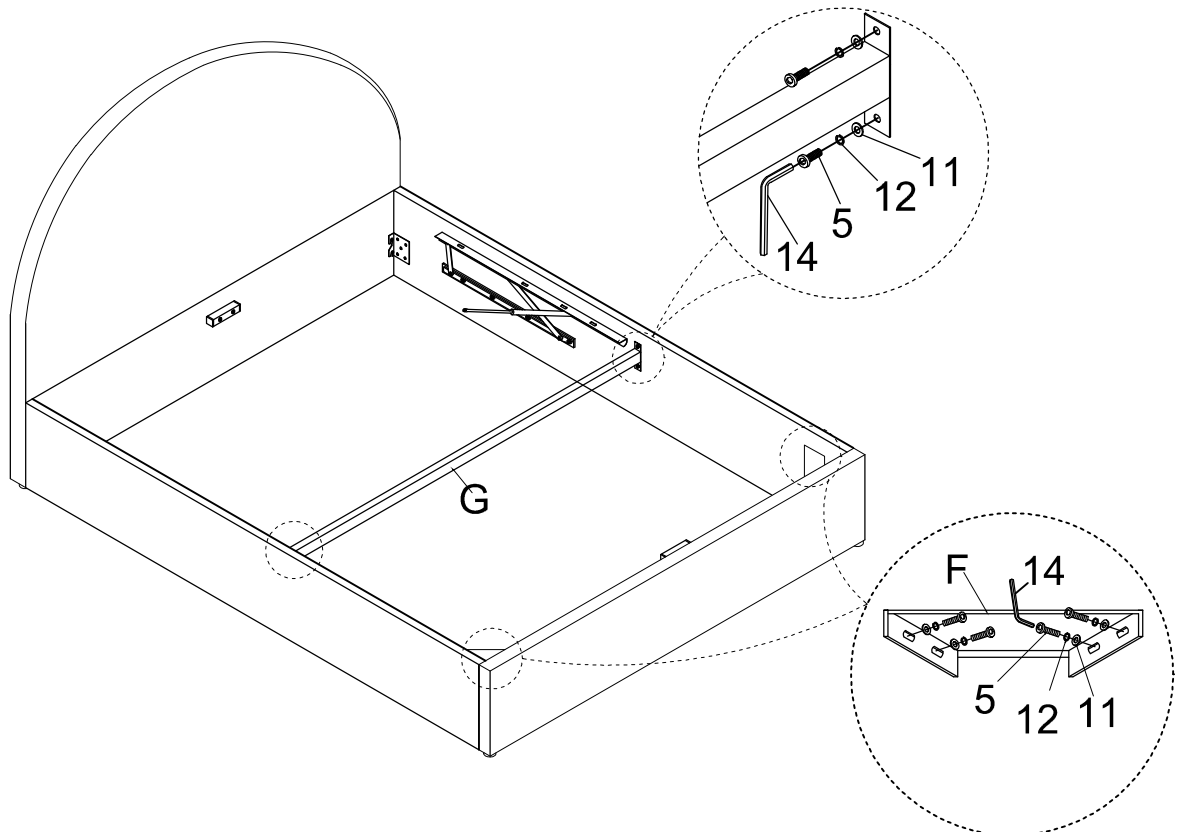

STEP 3

5		12PCS
	M6X20mm	
11		12PCS
	M6	
12		12PCS
	M6	
14		
	M6	







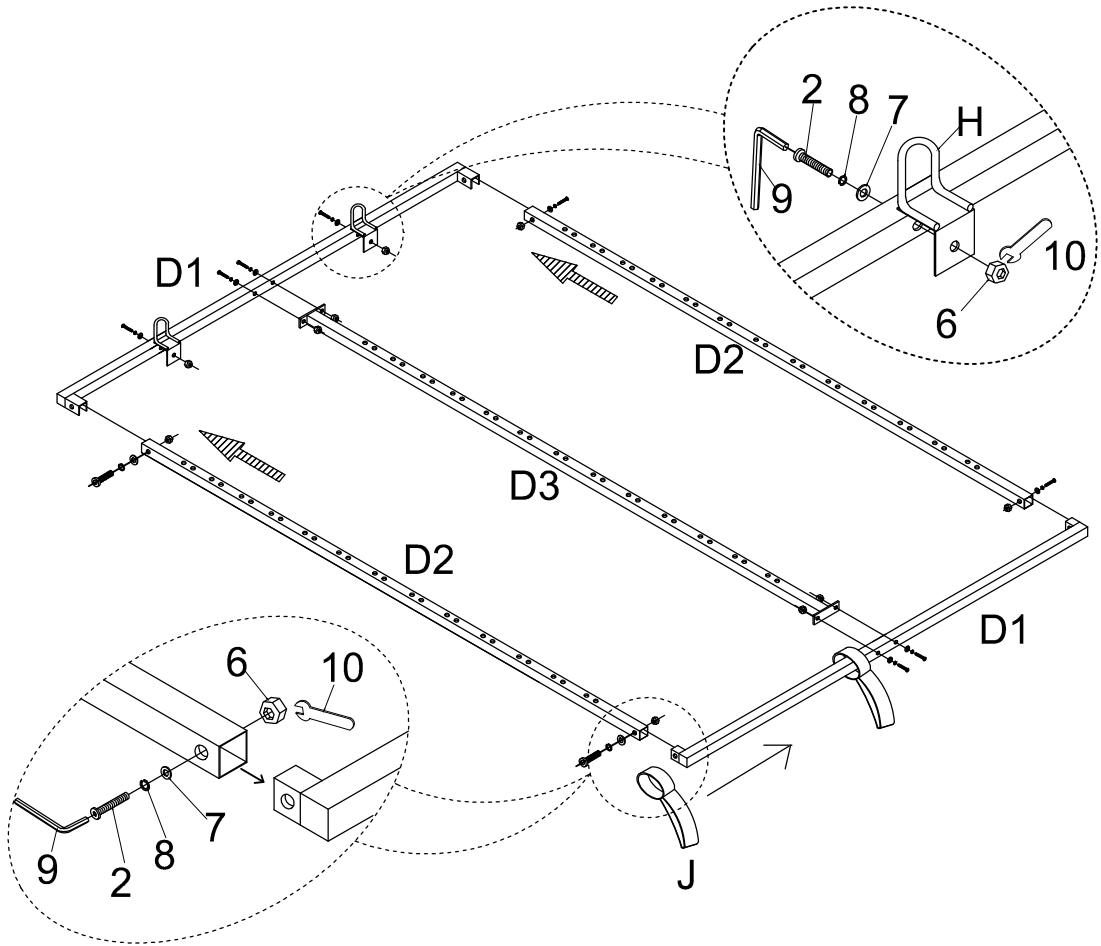

STEP 4

2		10PCS
	M8X45mm	
7		10PCS
	M8	
8		10PCS
	M8	
6		10PCS
10		
9		
	M8	



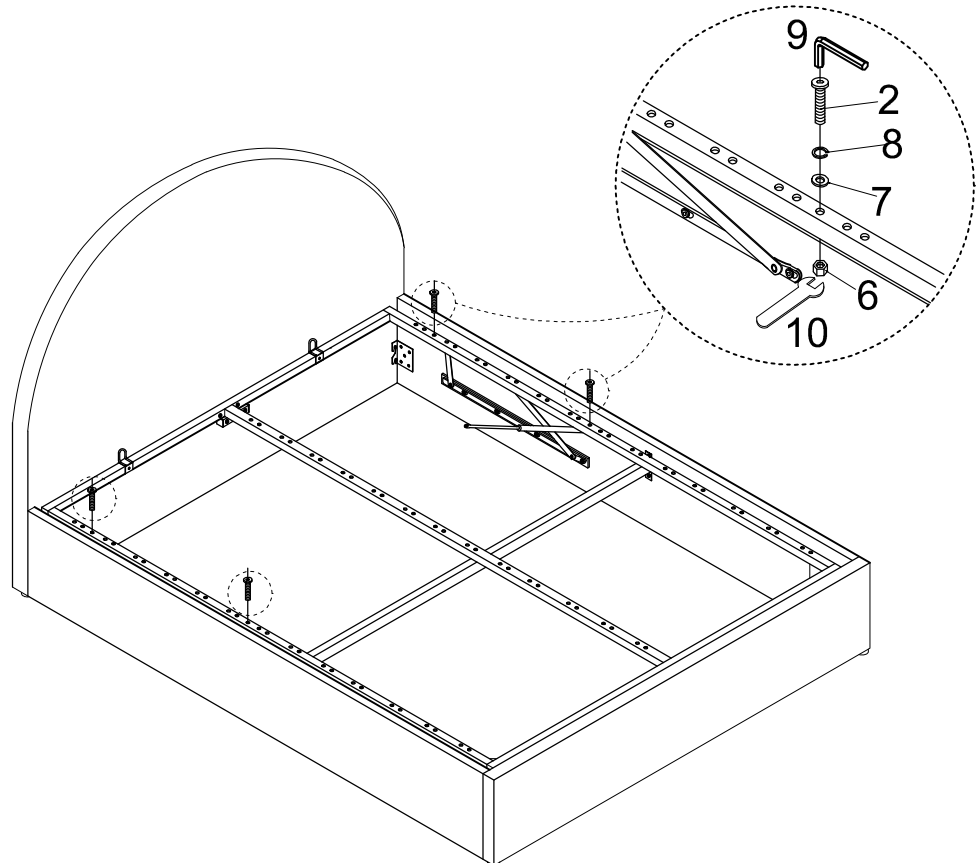

STEP 5

2		4PCS
	M8X45mm	
7		4PCS
	M8	
8		4PCS
	M8	
6		4PCS
10		
9		
	M8	



STEP 6

- O  26PCS
- N  13PCS

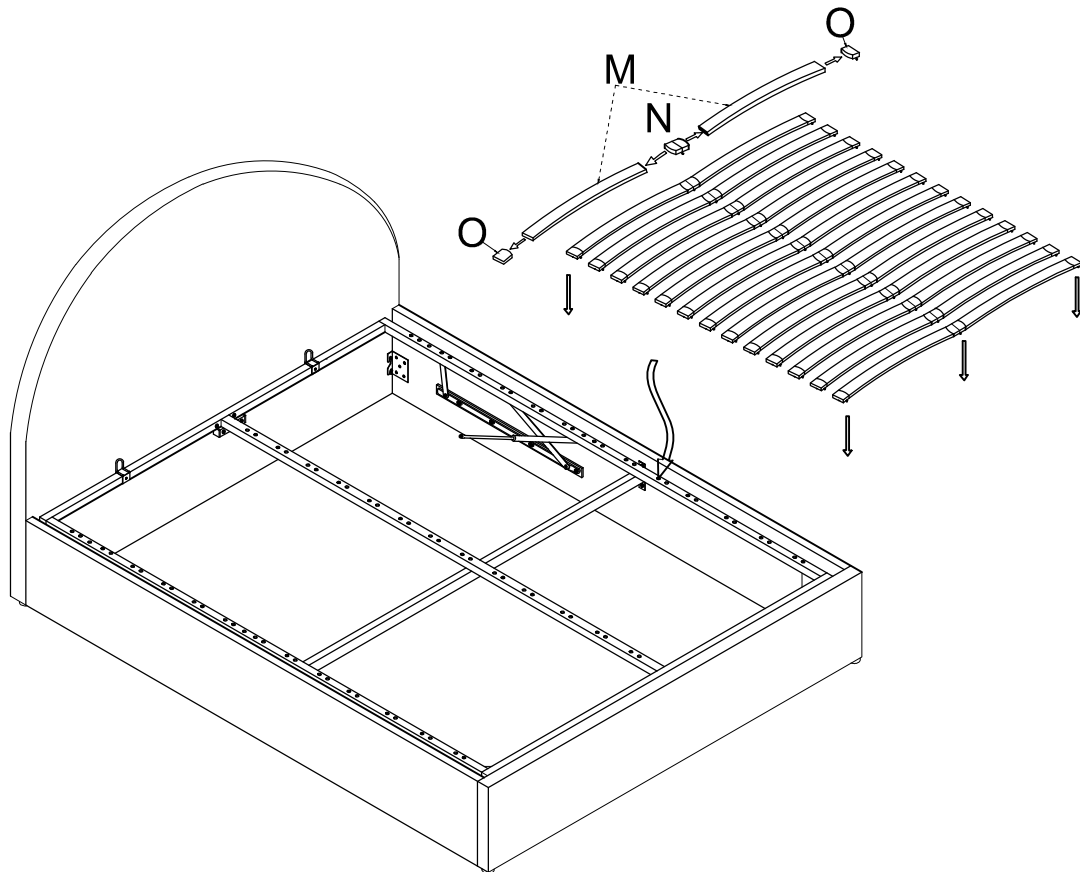

STEP 7

- 13 

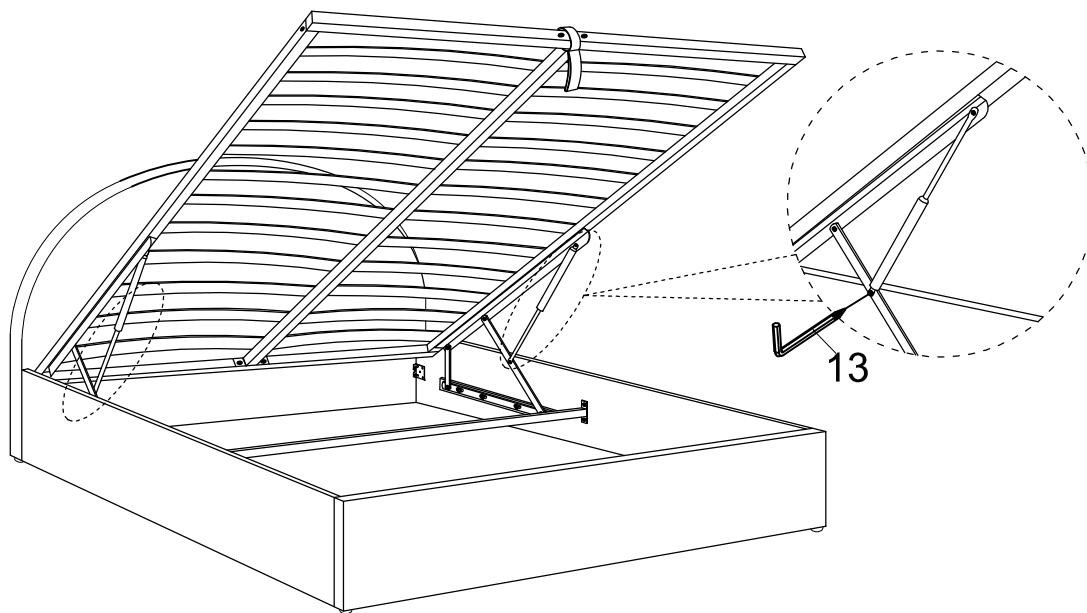

STEP 8

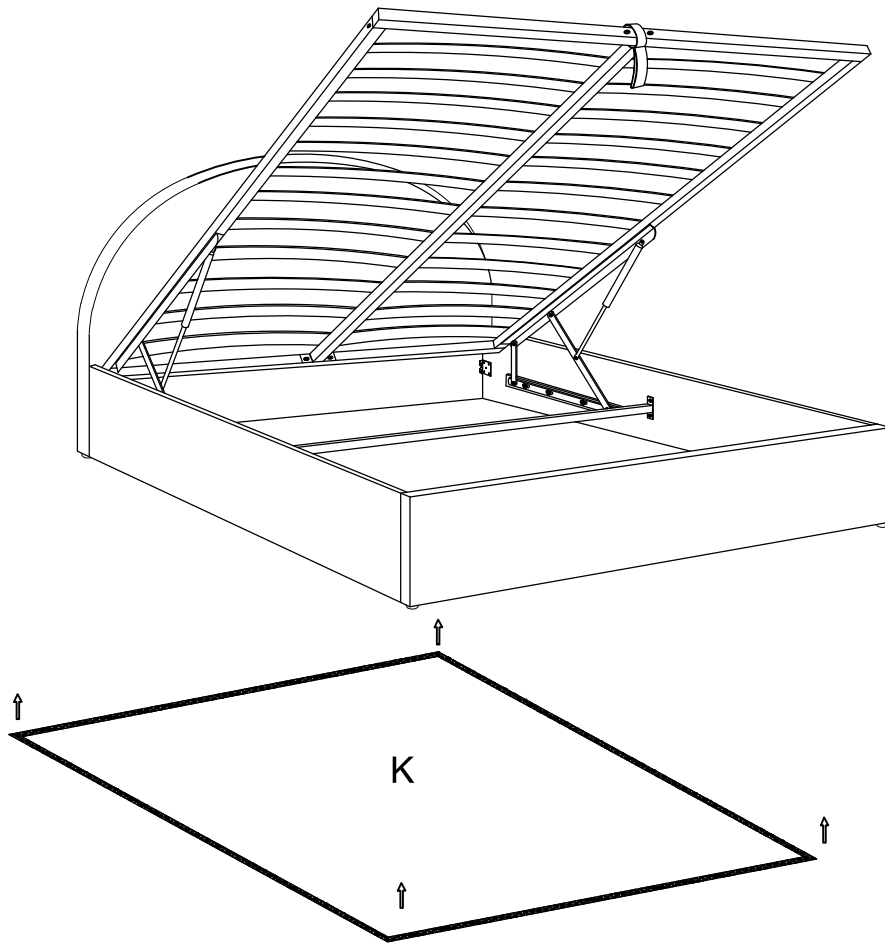

STEP 9

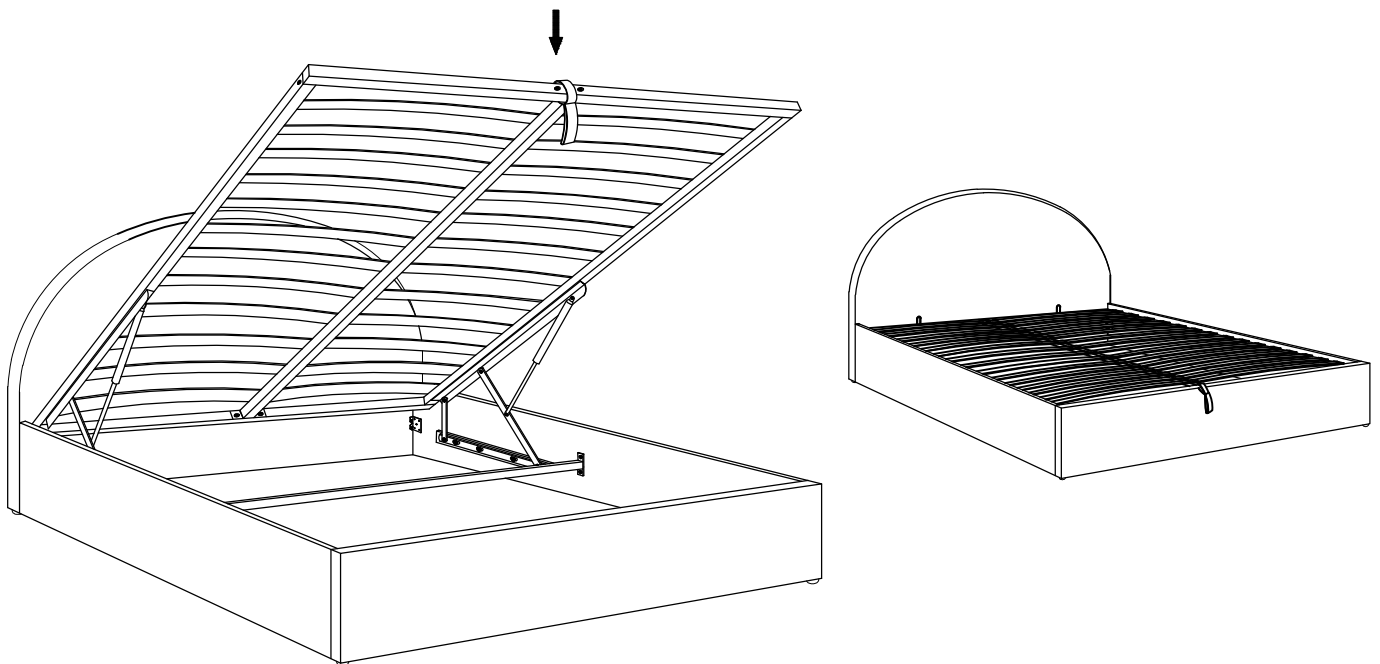

Press down the slats frame please use hands pressing on the points as the drawing showed. The bed has a pair of high pressure gas lift struts (75kgs each). After the bed frame is assembled, you will need to pull the metal frame down pretty hard, so that you can put slats on. After you add the mattress on the metal frame, the frame would be much easier to be closed down.